

# Data sheet

## LITHIUM POLYMER BATTERY

**1 YEAR  
WARRANTY**

### FEATURES OF LIPO BATTERY

- Low Self Discharge Rate
- Long Cycle Life
- Light Weight
- More Safety
- More Reliable

### LIPO BATTERY SPECIFICATION

Part Number	LP 501730
Nominal Voltage	3.7V
Nominal Capacity	180 mAh
Internal Impedance	< 60mΩ
Charge Voltage	4.2V
Recommended Charge Current	0.2C
Allowed Max Charge Current	0.5C
-Output Voltage Range	4.2-2.5V
Recommend Discharge Current	0.2C
Max Continuous Discharge Current	1C
Pulse Discharge Current	3C
Discharge Cut-off Voltage	2.5±0.05V
Cycle Life to 80% Health	500(0.2C,25°C)

### ENVIRONMENTAL SPECIFICATION

Charging Temperature Range	0-45°C
Discharging Temperature Range	-20-60°C
Storage Period 1 Week	-20-45°C
Storage Period 1 Month	-10-45°C
Storage Period 6 Months	0-35°C

### BATTERY PROTECTION

Over Charge	4.275±50mV
Over Discharge	2.5±50mV
Over Current	3A to 5A
Short Circuit	Yes

### MECHANICAL SPECIFICATION

Dimension	32×17×5.0 mm
Weight	≤5 g
Battery Terminals	WC/FL*

### CERTIFICATION

Certification Approval	CE/UL/UN38.3/CUSTOMIZED
------------------------	-------------------------

\*WC=With Connector FL=Flying Leads

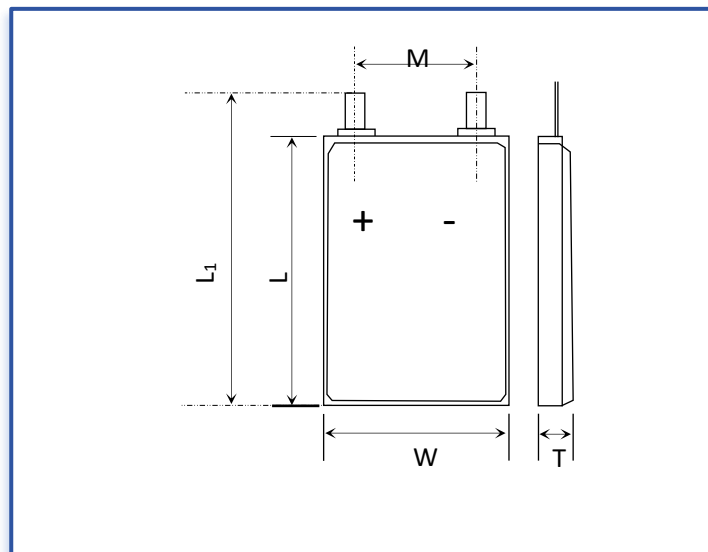

Item	Parameter (mm)
T	5.0
W	17
M	8
L	30
L <sub>1</sub>	32
BL	32±1
CL	100

